

**INSTRUCTIONS FOR CONTINUED AIRWORTHINESS  
FOR RADAR ALTIMETER ANTENNA INSTALLATION PROVISIONS**

**INSTRUCTIONS FOR CONTINUED AIRWORTHINESS**

**FOR**

**Helifab, Inc. Radar Altimeter Antenna Installation Provisions**

**STC No: \_\_\_\_\_**

**On**

**Bell Helicopter Model 206B, 206L, 206L-1, 206L-3, 206L-4 and 407**

**REPORT NUMBER:**

**HF-CA-7-6**



**1318 Smede Hwy.  
Broussard, La 70518  
Tel: (337)-298-9368**

**[www.ArrowAviationCo.com](http://www.ArrowAviationCo.com)**

**INSTRUCTIONS FOR CONTINUED AIRWORTHINESS  
FOR RADAR ALTIMETER ANTENNA INSTALLATION PROVISIONS**

THIS MANUAL IS PREPARED TO PROVIDE INFORMATION, INSTRUCTIONS FOR CONTINUED AIRWORTHINESS FOR EQUIPMENT MANUFACTURED BY HELIFAB THAT MAY BE INSTALLED. ENSURE THAT THIS MANUAL IS USED FOR ONLY HELIFAB EQUIPMENT.

**Table of Contents**

Log of Revisions.....	3
List of Effective Pages.....	3
1. INTRODUCTION.....	4
1.1. Revisions and Distribution.....	4
1.2. Scope of ICA.....	4
1.3. Precautions.....	4
1.4. Abbreviations.....	5
1.5. Consumable Materials.....	5
2. General Product Information and Description.....	5
3. AIRWORTHINESS LIMITATIONS.....	7
4. INSPECTIONS / MAINTENANCE.....	7
4.1. Special Tools Required.....	7
4.2. Special Materials Required.....	7
4.3. Conditional Inspections after Operational Incidents.....	7
4.4. Preflight Inspection.....	7
4.5. 100 Hour Inspection.....	8
4.6. 12 Month / Annual Inspection.....	9
4.7. Troubleshooting.....	10
4.8. Repairs.....	10
5. REMOVAL AND INSTALLATION INSTRUCTIONS / PARTS BREAKDOWN.....	10
5.1. Antenna or Antenna Mounts.....	10
5.1.1. Removal.....	10
5.1.1.1. Antenna.....	10
5.1.1.2. Antenna Mount Provisions.....	10
5.1.2. Installation.....	10
5.1.2.1. Antenna.....	10
5.1.2.2. Antenna Mount Provisions.....	10
5.2. Parts Breakdown.....	11
6. PLACARDS.....	12
7. WEIGHT AND BALANCE.....	12
APPENDIX A.....	13
Parts Breakdown.....	13

INSTRUCTIONS FOR CONTINUED AIRWORTHINESS  
FOR RADAR ALTIMETER ANTENNA INSTALLATION PROVISIONS

**Log of Revisions**

<b>REV No.</b>	<b>DESCRIPTION OF CHANGE</b>	<b>DATE ISSUED</b>	<b>DRAFTED BY</b>
<b>IR</b>	<b>Initial Release</b>	<b>01/25/2016</b>	<b>KDS</b>

**List of Effective Pages**

<b>PAGE</b>	<b>REVISION No.</b>	<b>DATE</b>
<b>1 thru 12 and A-1 thru A-12</b>	<b>IR</b>	<b>01/25/2016</b>

# INSTRUCTIONS FOR CONTINUED AIRWORTHINESS FOR RADAR ALTIMETER ANTENNA INSTALLATION PROVISIONS

## 1. INTRODUCTION

The purpose of these Instructions for Continued Airworthiness (ICA), is to provide required procedures for maintaining continued airworthiness for Helifab's radar altimeter antenna installation provisions.

### 1.1. Revisions and Distribution

These instructions are provided with each radar altimeter antenna installation provision kit. Any airworthiness or flight safety revisions will be sent to all who purchased the affected kits. A log of revisions is included in these instructions. Changes to this ICA are to be incorporated and are identified as follows:

Revised or extended text and inserted pages with new text contents or new figures are identified with black marginal bars or referenced symbols. When text is relocated resulting in a renumbering of pages or task, or in case of printing error corrections, no markings are provided.

### 1.2. Scope of ICA

The purpose of this ICA is to provide necessary information to maintain, inspect, repair, or replace the equipment. Maintenance personnel should be thoroughly familiar with standard abbreviations contained herein. Specific abbreviations or acronyms can be found in the document text with the full meaning. Requests for replacement ICA should be made to:

**Address:**  
Helifab  
1318 Smede Hwy.  
Broussard, La 70518  
**Telephone:** (337)364-4357

**Website:** [www.ArrowAviationCo.com](http://www.ArrowAviationCo.com)

### 1.3. Precautions

The following precautions may be used throughout this manual and are defined as follows:

- |                |   |
|----------------|---|
| <b>WARNING</b> | IS USED WHEN UNQUALIFIED PERFORMANCE OR NEGLECT OF INSTRUCTIONS MAY LEAD TO INJURIES OR DEADLY ACCIDENTS. |
| <b>CAUTION</b> | IS USED WHEN UNQUALIFIED PERFORMANCE OR NEGLECT OF INSTRUCTIONS MAY LEAD TO EQUIPMENT DAMAGE              |
| <b>NOTE</b>    | IS USED WHEN A PARTICULAR ITEM NEEDS TO BE EMPHASIZED   |

INSTRUCTIONS FOR CONTINUED AIRWORTHINESS  
FOR RADAR ALTIMETER ANTENNA INSTALLATION PROVISIONS

**1.4. Abbreviations**

The following Abbreviations may be used throughout this manual and are defined as follows:

EMM	Equipment Maintenance Manual
ICA	Instructions for Continued Airworthiness
HF	Helifab
MIL	US Military Specification
N/C	No Change
Mo.	Months
Y	Years
PN	Part Number
IAW	In Accordance With
LH	Left Hand
RH	Right Hand
NA	Not Applicable
Cont.	Continued
FWD	Forward
CG	Center of Gravity

**1.5. Consumable Materials**

- A. Explanation  
Only Consumable materials noted throughout this manual and on referenced drawings are to be used. Helifab, Inc. can be contacted to approve alternate or equivalent materials.

**2. General Product Information and Description**

Helifab, Inc. radar altimeter antenna installation installs provisions for radar altimeter antennas on either the tailboom or aft lower fairing below the baggage compartment. There are four installation dash numbers as defined below:

Part Number: HF-N-7-6-1 407 Radar Altimeter Antenna Provisions Installation Kit:

This installation kit is for the Bell 407 model and installs two radar altimeter antenna mounts to the tailboom..

Part Number: HF-N-7-6-2 206L Series and 206B Radar Altimeter Antenna Provisions Installation Kit:

This installation kit is for the Bell 206B, 206L, 206L-1, 206L-3, and 206L-4 models and installs two radar altimeter antenna mounts to the tailboom.

INSTRUCTIONS FOR CONTINUED AIRWORTHINESS  
FOR RADAR ALTIMETER ANTENNA INSTALLATION PROVISIONS

Part Number: HF-N-7-6-3 206L series and 407 Radar Altimeter Antenna Provisions  
Installation Kit:

This installation kit is for the Bell 206L, 206L-1, 206L-3, 206L-4 and 407 models and installs two radar altimeter antenna mounts to the aft lower fairing.

Part Number: HF-N-7-6-4 206B Radar Altimeter Antenna Provisions Installation Kit:

This installation kit is for the Bell 206B model and installs two radar altimeter antenna mounts to the aft lower fairing. This installation allows for an optional access hole cutout in the aft lower fairing for ease of access to the inner side of the fairing.

INSTRUCTIONS FOR CONTINUED AIRWORTHINESS  
FOR RADAR ALTIMETER ANTENNA INSTALLATION PROVISIONS

**3. AIRWORTHINESS LIMITATIONS**

There are no overhauls, time limits, or airworthiness limitations associated with this type design change.

The Airworthiness Limitations section is FAA approved and specifies inspections and other maintenance required under Secs. 43.16 and 91.403 of the Federal Aviation Regulations unless an alternative program has been FAA approved.

**4. INSPECTIONS / MAINTENANCE**

**4.1. Special Tools Required**

Any special tools required for maintenance, removal, or installation of the radar altimeter antenna mounts will be specified in the text of this document where applicable.

**4.2. Special Materials Required**

Any consumable materials required for maintenance, removal, or installation of the radar altimeter antenna mounts will be specified in the text of this document where applicable.

**4.3. Conditional Inspections after Operational Incidents**

After any operational incident involving hard landings, sudden stoppage of the drive train or water immersion, the system must not be operated until a thorough inspection of the installation has been accomplished IAW section 4.5 of this document.

**4.4. Preflight Inspection**

Normal pre-flight inspections to be accomplished per Bell Helicopter rotorcraft flight manual.

INSTRUCTIONS FOR CONTINUED AIRWORTHINESS  
FOR RADAR ALTIMETER ANTENNA INSTALLATION PROVISIONS

**4.5. 100 Hour Inspection**

This inspection is to be performed by a qualified technician.

All inspections must be recorded in the rotorcraft records IAW 14 CFR Part 43 or other applicable regulations.

INSPECTION TASK DESCRIPTION	
<p>1. Inspect antenna mounts and doublers for security, general condition, nicks, scratches, corrosion, dents, and cracks. Inspect for loose, missing, or working fasteners.</p> <p>Damage limits are listed in table 1 of this document.</p> <p>If damage is within damage limits listed in table 1, follow the instructions for repair listed below:</p> <p><b>Corrosion:</b> Blend out corrosion using 320 grit or finer aluminum oxide abrasive paper. A 10:1 width to depth ration of cleanup is to be maintained. Corrosion cleanup must be twice the depth of the corrosion. After repair, prime bare surfaces using primer per MIL-P-23377 and topcoat as required.</p> <p><b>Scratches or Nicks:</b> Blend out scratches or nicks using 320 grit or finer aluminum oxide abrasive paper. A 10:1 width to depth ration of cleanup is to be maintained. After repair, prime bare surfaces using primer per MIL-P-23377 and topcoat as required.</p>	
<p>2. Inspect surrounding structure around antenna mounts for corrosion, cracking, or other damage. For repair to surrounding structure, refer to applicable Manufacturer's maintenance manual.</p>	



INSTRUCTIONS FOR CONTINUED AIRWORTHINESS  
FOR RADAR ALTIMETER ANTENNA INSTALLATION PROVISIONS

**4.6. 12 Month / Annual Inspection**

This inspection is to be performed by a qualified technician.

All inspections must be recorded in the rotorcraft records IAW 14 CFR Part 43 or other applicable regulations.

INSPECTION TASK DESCRIPTION	
<p>3. Inspect antenna mounts and doublers for security, general condition, nicks, scratches, corrosion, dents, and cracks. Inspect for loose, missing, or working fasteners.</p> <p>Damage limits are listed in table 1 of this document.</p> <p>If damage is within damage limits listed in table 1, follow the instructions for repair listed below:</p> <p><b>Corrosion:</b> Blend out corrosion using 320 grit or finer aluminum oxide abrasive paper. A 10:1 width to depth ration of cleanup is to be maintained. Corrosion cleanup must be twice the depth of the corrosion. After repair, prime bare surfaces using primer per MIL-P-23377 and topcoat as required.</p> <p><b>Scratches or Nicks:</b> Blend out scratches or nicks using 320 grit or finer aluminum oxide abrasive paper. A 10:1 width to depth ration of cleanup is to be maintained. After repair, prime bare surfaces using primer per MIL-P-23377 and topcoat as required.</p>	
<p>4. Inspect surrounding structure around antenna mounts for corrosion, cracking, or other damage. For repair to surrounding structure, refer to applicable Manufacturer's maintenance manual.</p>	

**Table 1  
Damage and Repair Limits**

Item	Maximum Damage Limits	
	Cracks	Dents or Scratches
<b>Radius Blocks</b>	None Allowed	Maximum Depth After Cleanup .020 inches *
<b>Doublers</b>	None Allowed	Maximum Depth after Cleanup .010 inches *

\*Depths listed are maximum based on original thickness of part. If the same area is repaired multiple times, the total combined depth of all repairs must not exceed the maximum depth listed.

# INSTRUCTIONS FOR CONTINUED AIRWORTHINESS FOR RADAR ALTIMETER ANTENNA INSTALLATION PROVISIONS

## 4.7. Troubleshooting

Replace any parts that do not function properly or that cannot be repaired in accordance with the instructions given in this manual.

## 4.8. Repairs

No repairs other than those that can be accomplished with FAA accepted methods or that are called out in this document are allowed.

## 5. REMOVAL AND INSTALLATION INSTRUCTIONS / PARTS BREAKDOWN

### 5.1. Antenna or Antenna Mounts

#### Note

Fastener installation to be in accordance with FAA Advisory Circular AC43-13-1B, Chapter 7.  
Use standard torques for all fasteners.

#### 5.1.1. Removal

##### 5.1.1.1. Antenna

1. To remove an antenna installed to the provisions, remove the four screws attaching the antennas (two antenna locations) and install four each MS27039 # 10 screw and NAS1149 D0332K washers in the antenna attachment holes.

##### 5.1.1.2. Antenna Mount Provisions

1. To remove the antenna mount installation provisions, remove all screws and rivets attaching the radius blocks and doublers. Remove doublers and radius blocks from the aircraft. Repair holes in the fuselage from the previously installed antenna installation provisions in accordance with FAA approved data.

#### 5.1.2. Installation

##### 5.1.2.1. Antenna

1. Remove the four MS27039 #10 screws and four NAS1149D0332K washers at each antenna installation location. Install antenna per antenna manufacturer instructions using antenna manufacturer specified hardware. If no hardware is specified, install antennas using four each MS24694 #10 cadmium plated screws (four screws per antenna location).

##### 5.1.2.2. Antenna Mount Provisions

1. Reinstall antenna mount provisions in accordance with current STC installation instructions.

INSTRUCTIONS FOR CONTINUED AIRWORTHINESS  
FOR RADAR ALTIMETER ANTENNA INSTALLATION PROVISIONS

**5.2. Parts Breakdown**

Reference appendix A

**Table 1  
Parts List**

Item Number	Part Number	Nomenclature	Vendor / Manufacturer	Note
1	RESERVED			
2	RESERVED			
3	RESERVED			
4	RESERVED			
5	HF-A-7-6-1	INNER RADIUS BLOCK	HELIFAB	
6	HF-A-7-6-2	INNER RADIUS BLOCK	HELIFAB	
7	HF-D-7-6-3	OUTER RADIUS BLOCK	HELIFAB	
8	HF-D-7-6-4	OUTER RADIUS BLOCK	HELIFAB	
9	HF-A-7-6-3	AFT 407 INNER RADIUS BLOCK	HELIFAB	
10	HF-D-7-6-6	AFT 407 OUTER RADIUS BLOCK	HELIFAB	
11	HF-D-7-6-8	206 FWD DOUBLER	HELIFAB	
12	HF-D-7-6-9	206 AFT DOUBLER	HELIFAB	
13	HF-D-7-6-10	407 FWD DOUBLER	HELIFAB	
14	HF-D-7-6-11	407 AFT DOUBLER	HELIFAB	
15	MS35489-49	GROMMET	HELIFAB	
16	CR3212-4	BLIND FLUSH RIVET	CHERRY AEROSPACE	
17	CR3213-4	BLIND RIVET	CHERRY AEROSPACE	
18	MS27039-1-24	#10 CADMIUM PLATED SCREW		(3)(4)
19	NAS1149D 0332J	WASHER		(1)
20	HF-D-7-7	TAPERED BLOCK	HELIFAB	
21	HF-A-7-6-4	INNER DOUBLER	HELIFAB	
22	HF-A-7-6-5	INNER RING DOUBLER	HELIFAB	
23	HF-D-7-15	OUTER RING DOUBLER	HELIFAB	
24	HF-D-7-16	COVER	HELIFAB	
25	RESERVED			
26	RESERVED			
27	MS27039-1-10	SCREW		(3)
28	RESERVED			
29	HF-D-7-17	SHIM		
30	MS27039-1-26	#10 CADMIUM PLATED SCREW		(3)(4)
31	MS21042L3	NUT		(2)
32	91944A204	FRMALE WASHER		(6)
33	91944A104	MALE WASHER		(6)
34	91944A027	ALIGNING WASHER ASSY	MCMMASTER CARR	(6)

- (1) NAS1149D 0332K can be used as an alternate for item 19.
- (2) MS21042-3 can be used as alternate for item 31.
- (3) Fastener length may be changed from that shown if required for proper engagement. Threaded fasteners should not extend past nut or nutplate more than .5 inches. Fastener should not interfere or contact surrounding structure.
- (4) Reference antenna installation instructions for screw type to be used when antenna is installed or MS24694 #10 cadmium plated steel screws if none are specified.
- (5) If desired, coverplates (3.63 x 3.8 inches in size) for the antenna mount locations may be locally fabricated from 0.040 2024-T3 per AMS-QQ-A-250/4 or /5 and installed using existing MS27039#10 screws in the antenna mount provision installation.
- (6) Item 34 consists of item 32 and 33.

**INSTRUCTIONS FOR CONTINUED AIRWORTHINESS  
FOR RADAR ALTIMETER ANTENNA INSTALLATION PROVISIONS**

**6. PLACARDS**

There are no placards associated with this type design change.

**7. WEIGHT AND BALANCE**

The new empty weight and corresponding C.G. location must be determined and entered in the aircraft permanent records.

Installation of Helifab's radar altimeter antenna mount provisions has the following effect on weight and balance.

**Table 2  
Equipment Weights and Locations**

<b>Installation Part Number</b>	<b>Rotorcraft Model</b>	<b>Weight (Lb.)</b>	<b>Fuselage STA</b>	<b>BL</b>	<b>Notes</b>
HF-N-7-6-1	407	2.2 Lb.	269	0	(1)
HF-N-7-6-2	206B	2.0 Lb.	233.4	0	(1)
HF-N-7-6-2	206L Series	2.0 Lb.	260.5	0	(1)
HF-N-7-6-3	206L Series and 407	1	163.5	0	(1)
HF-N-7-6-4 (with optional fairing access hole)	206B	1.9	138.3	0	(1)
HF-N-7-6-4 (without optional fairing access hole)	206B	1	140.4	0	(1)

(1) Weight listed includes both antenna mounting provisions (two antenna positions). Antenna weight is not included and must also be accounted for.

INSTRUCTIONS FOR CONTINUED AIRWORTHINESS  
FOR RADAR ALTIMETER ANTENNA INSTALLATION PROVISIONS

**APPENDIX A**  
**Parts Breakdown**

INSTALLATION PART NUMBER  
 HF-N-7-6-2. INSTALLATION ON  
 BELL 206B, 206L, 206L-1, 206L-3,  
 AND 206L-4 ONLY

LHS  
 FWD  
 (VIEW LOOKING UP)

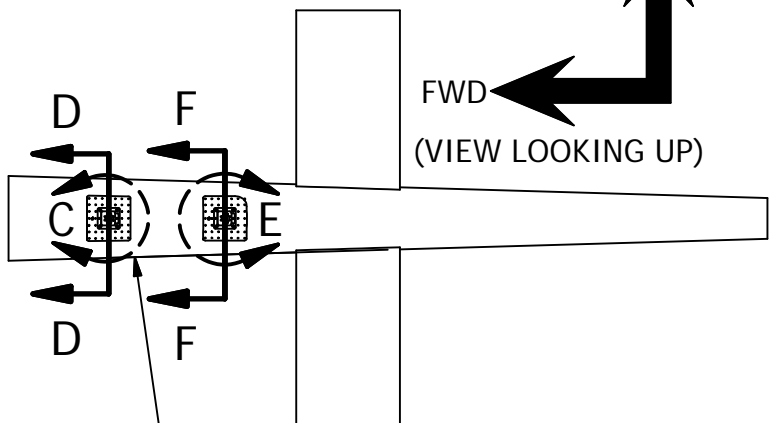

ANTENNA INSTALLATION  
 PROVISION ON TAILBOOM

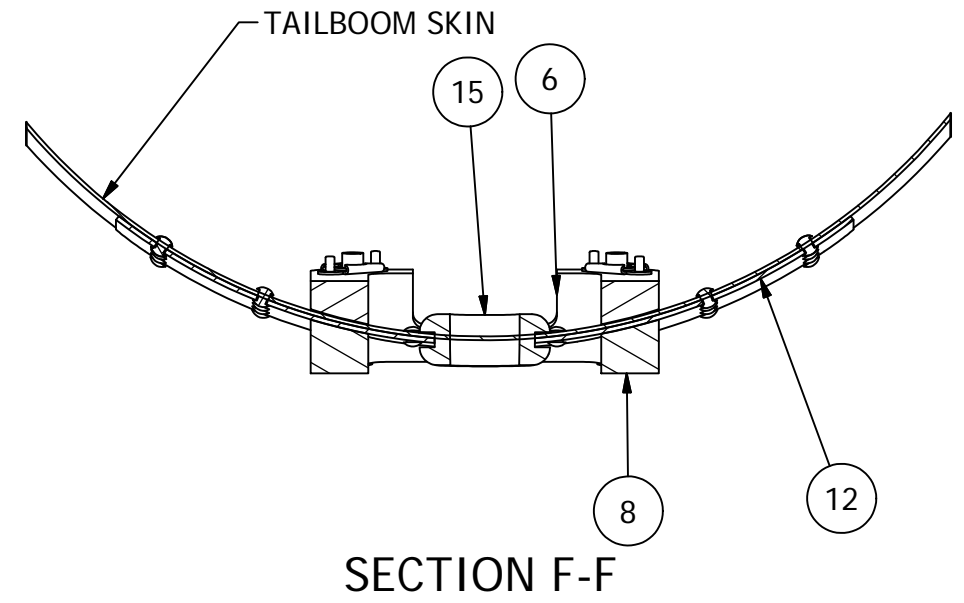
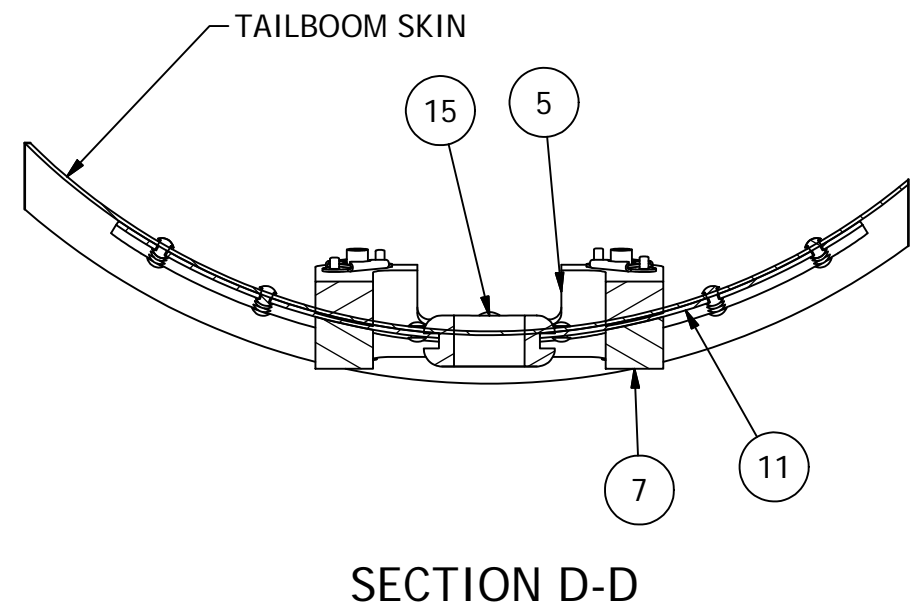
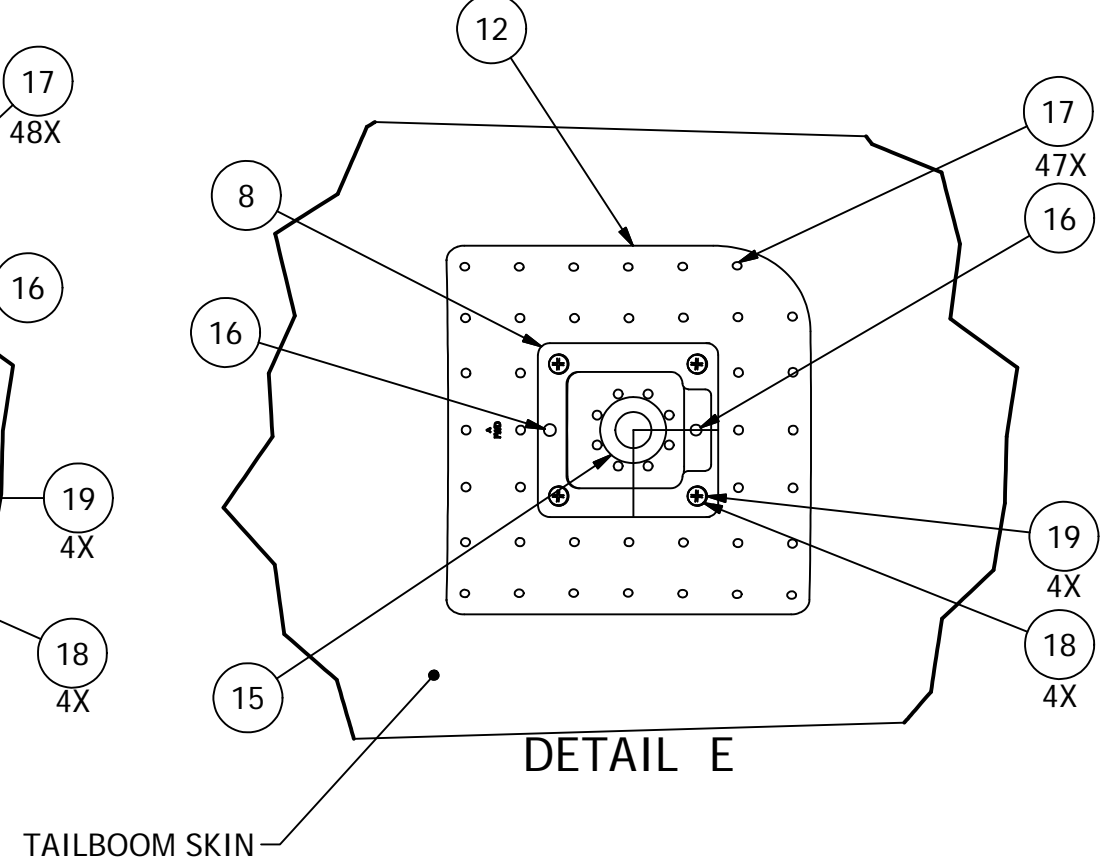
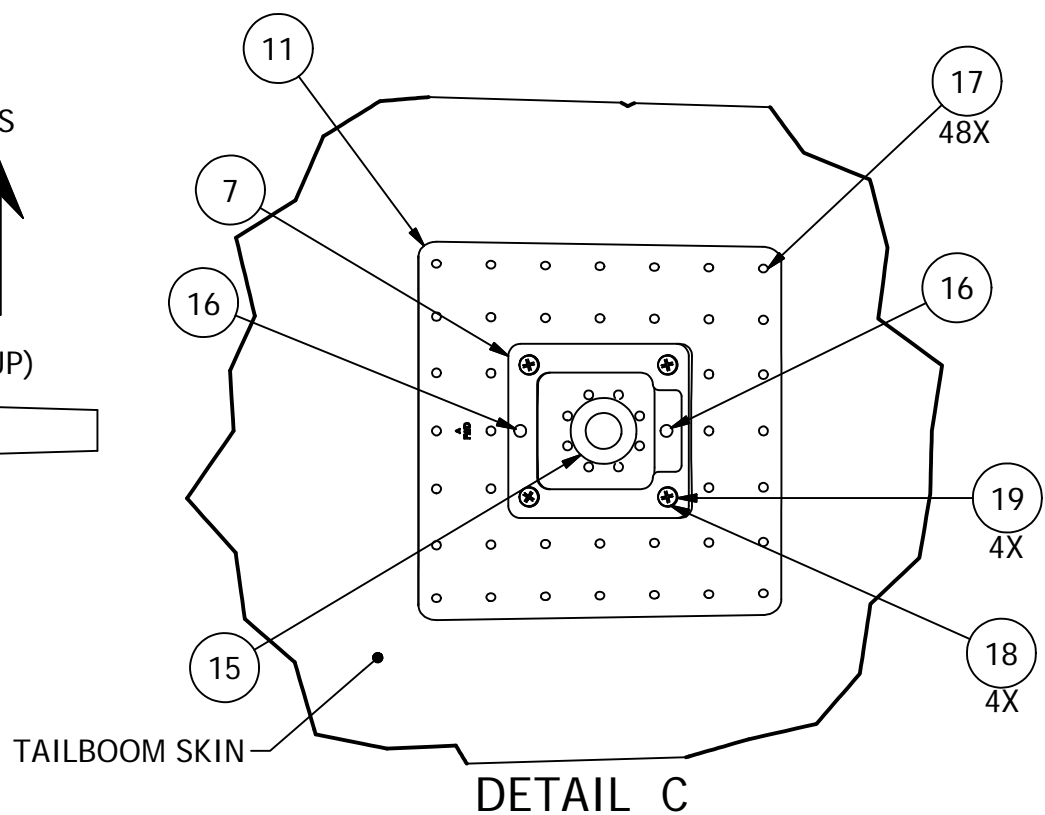

PROPRIETARY NOTICE  
 THIS DOCUMENT AND THE INFORMATION HEREIN ARE PROPRIETARY DATA TO HELIFAB  
 AND ALL DESIGN, MANUFACTURING, REPRODUCTION, USE, PATENT RIGHTS AND SALES RIGHTS  
 REGARDING THE SAME ARE EXPRESSLY RESERVED. THIS DATA IS SUBMITTED UNDER A  
 CONFIDENTIAL RELATIONSHIP FOR A SPECIFIC PURPOSE AND NEITHER THIS DOCUMENT NOR THE  
 INFORMATION CONTAINED HEREIN SHALL BE REPRODUCED, USED, OR DISCLOSED TO OTHERS



DRAWING NO:	HF-CA-7-6
LATEST REV/DATE:	IR / 01/25/2016
DRAWING SIZE:	B
SCALE:	NTS
SHEET:	A-2

**INSTALLATION PART NUMBER  
HF-N-7-6-1. INSTALLATION  
ON BELL 407 ONLY**

LHS  
FWD  
(VIEW LOOKING UP)

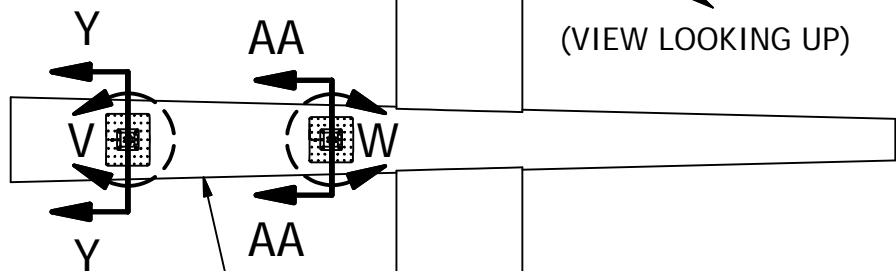

VIEW R-R

ANTENNA INSTALLATION  
PROVISION ON TAILBOOM

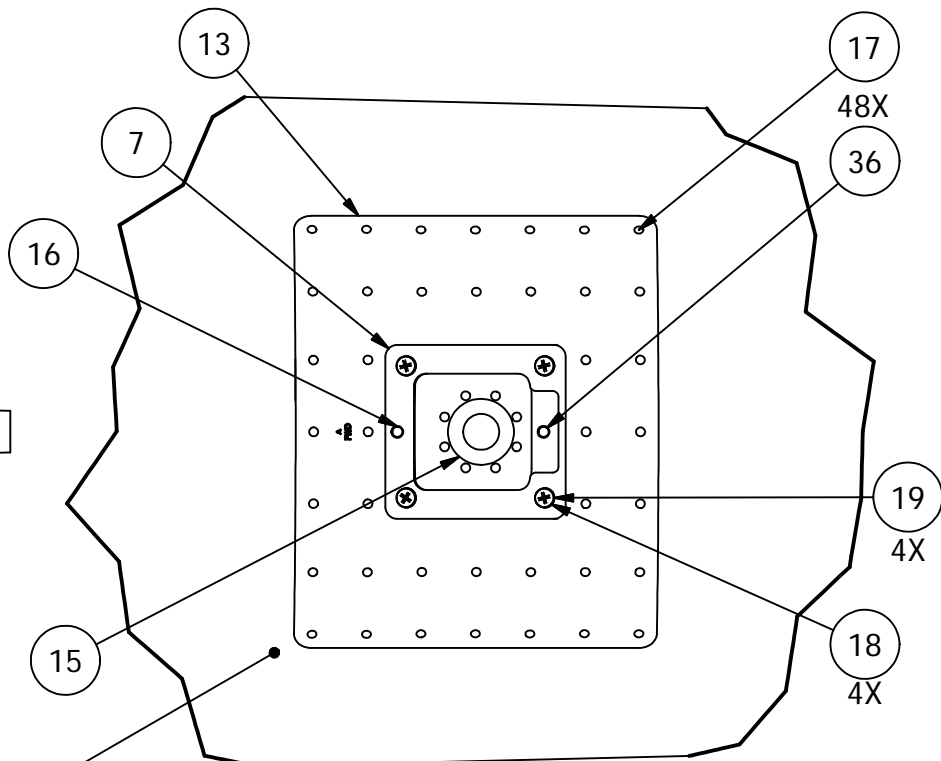

DETAIL V

TAILBOOM SKIN

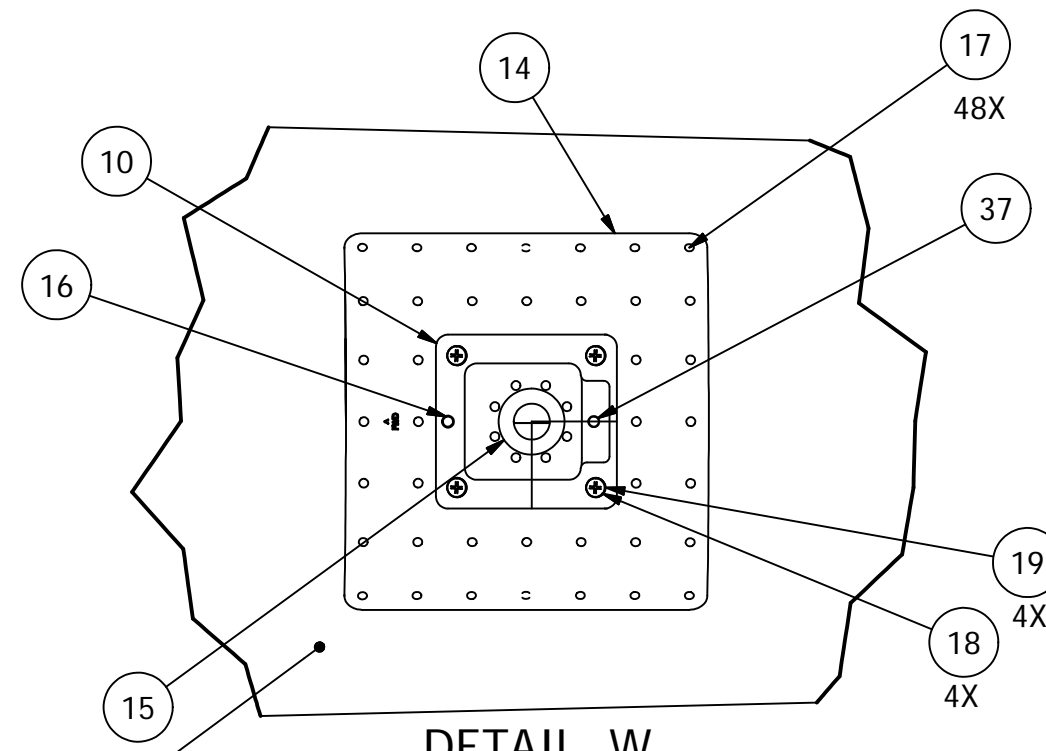

DETAIL W

TAILBOOM SKIN

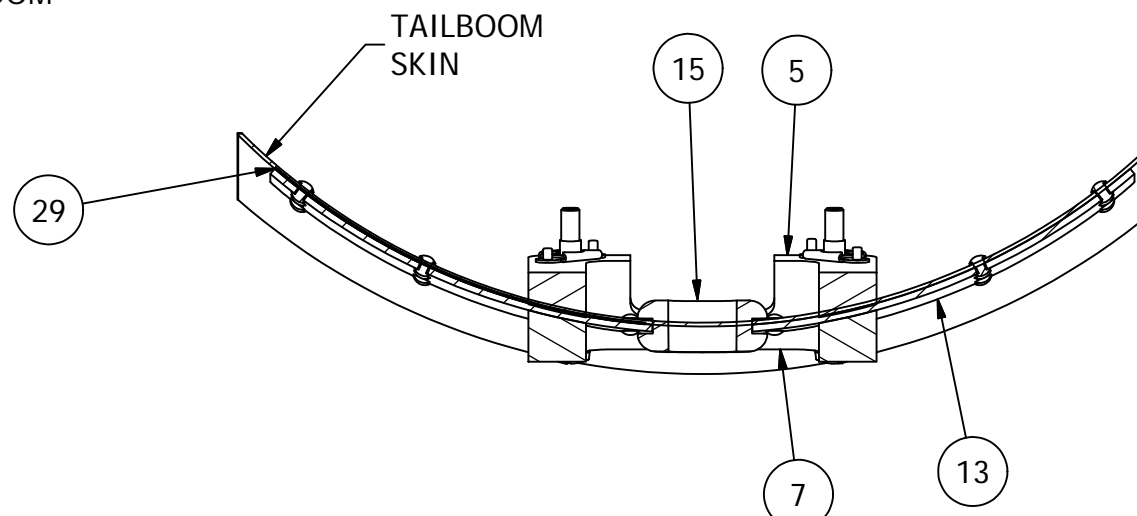

SECTION Y-Y

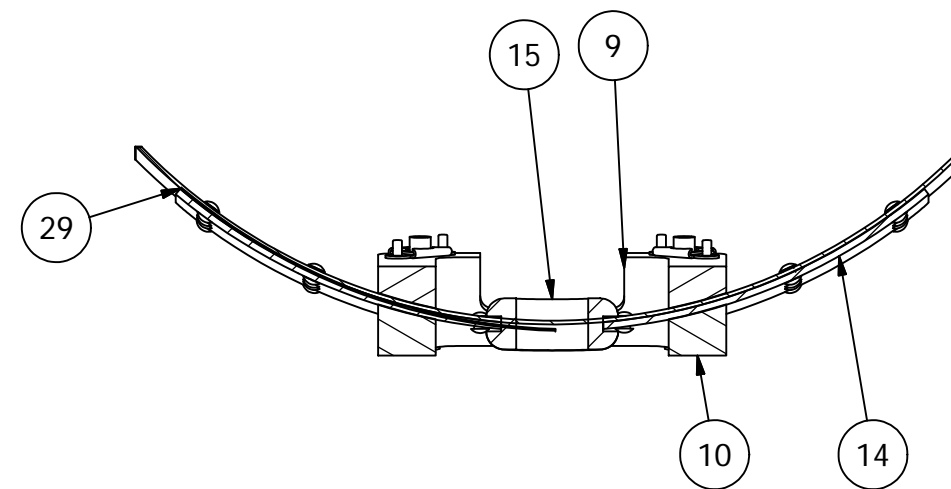

SECTION AA-AA

PROPRIETARY NOTICE  
THIS DOCUMENT AND THE INFORMATION HEREIN ARE PROPRIETARY DATA TO HELIFAB AND ALL DESIGN, MANUFACTURING, REPRODUCTION, USE, PATENT RIGHTS AND SALES RIGHTS REGARDING THE SAME ARE EXPRESSLY RESERVED. THIS DATA IS SUBMITTED UNDER A CONFIDENTIAL RELATIONSHIP FOR A SPECIFIC PURPOSE AND NEITHER THIS DOCUMENT NOR THE INFORMATION CONTAINED HEREIN SHALL BE REPRODUCED, USED, OR DISCLOSED TO OTHERS

**HELI FAB**

DRAWING NO:	HF-CA-7-6
LATEST REV/DATE:	IR / 01/25/2016
DRAWING SIZE:	B
SCALE:	NTS
SHEET:	A-3

INSTALLATION PART NUMBER  
 HF-N-7-6-3. INSTALLATION ON BELL  
 206L, 206L-1, 206L-3, 206L-4, AND  
 407 ONLY

ANTENNA INSTALLATION  
 PROVISION ON AFT LOWER FAIRING

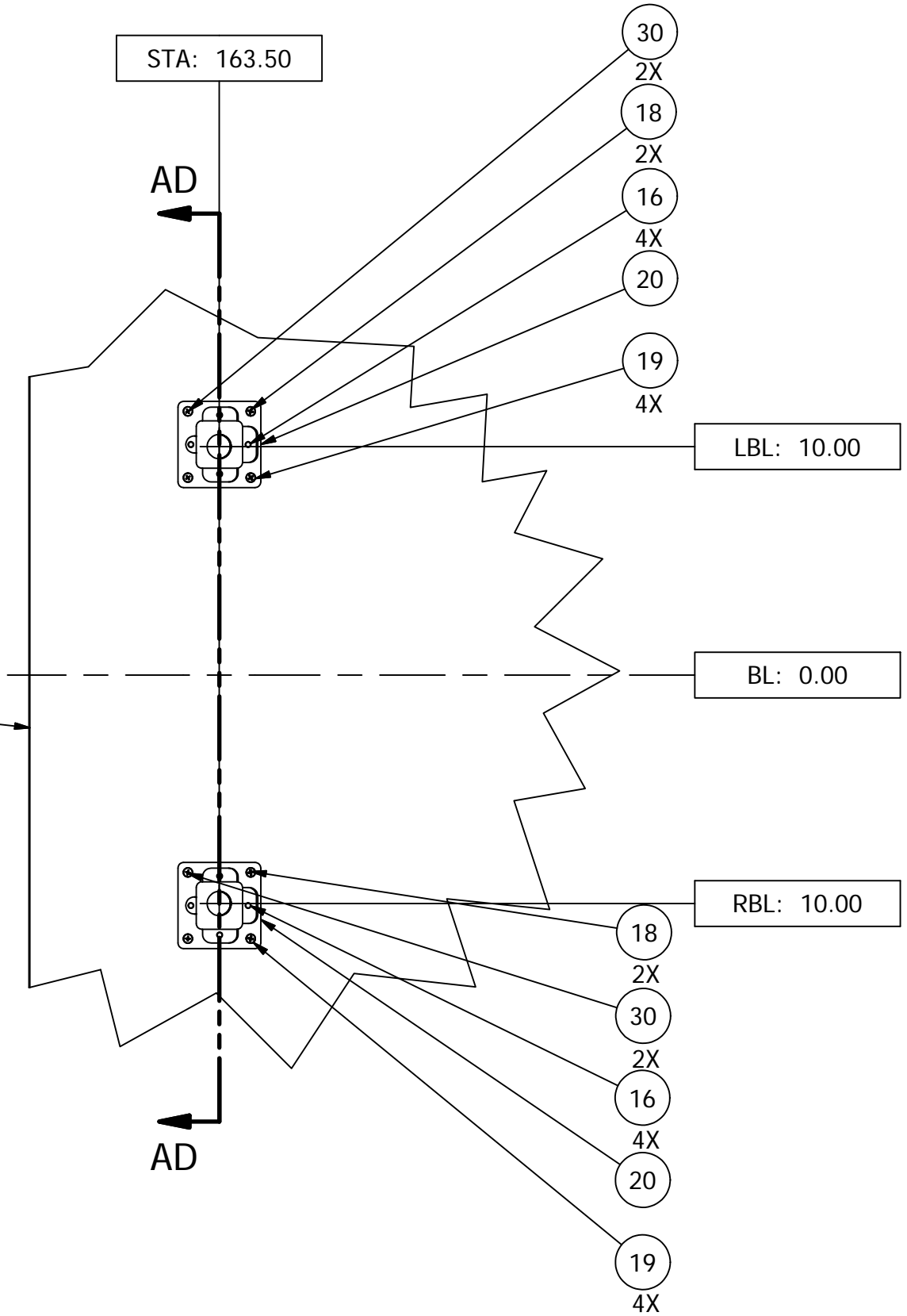

LHS  
 FWD  
 (VIEW LOOKING UP)

PROPRIETARY NOTICE  
 THIS DOCUMENT AND THE INFORMATION HEREIN ARE PROPRIETARY DATA TO HELIFAB AND ALL DESIGN, MANUFACTURING, REPRODUCTION, USE, PATENT RIGHTS AND SALES RIGHTS REGARDING THE SAME ARE EXPRESSLY RESERVED. THIS DATA IS SUBMITTED UNDER A CONFIDENTIAL RELATIONSHIP FOR A SPECIFIC PURPOSE AND NEITHER THIS DOCUMENT NOR THE INFORMATION CONTAINED HEREIN SHALL BE REPRODUCED, USED, OR DISCLOSED TO OTHERS



DRAWING NO:	HF-CA-7-6
LATEST REV/DATE:	IR / 01/25/2016
SHEET:	A-4

DRAWING SIZE:	B
SCALE:	NTS



INSTALLATION PART NUMBER  
 HF-N-7-6-3. INSTALLATION ON BELL  
 206L, 206L-1, 206L-3, 206L-4, AND  
 407 ONLY

UP  
 LEFT  
 (VIEW LOOKING FWD)

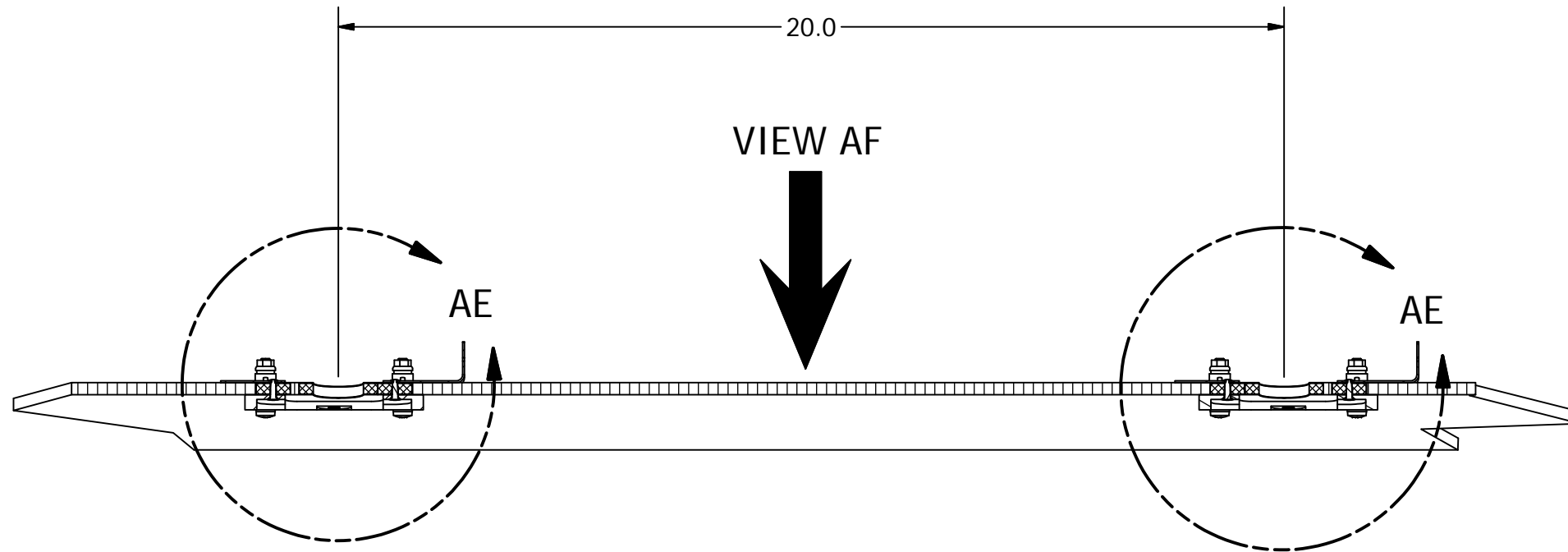

SECTION AD-AD

PROPRIETARY NOTICE  
 THIS DOCUMENT AND THE INFORMATION HEREIN ARE PROPRIETARY DATA TO HELIFAB  
 AND ALL DESIGN, MANUFACTURING, REPRODUCTION, USE, PATENT RIGHTS AND SALES RIGHTS  
 REGARDING THE SAME ARE EXPRESSLY RESERVED. THIS DATA IS SUBMITTED UNDER A  
 CONFIDENTIAL RELATIONSHIP FOR A SPECIFIC PURPOSE AND NEITHER THIS DOCUMENT NOR THE  
 INFORMATION CONTAINED HEREIN SHALL BE REPRODUCED, USED, OR DISCLOSED TO OTHERS



DRAWING NO:	HF-CA-7-6
LATEST REV/DATE:	IR / 01/25/2016
DRAWING SIZE:	B
SCALE:	NTS
SHEET:	A-5

INSTALLATION PART NUMBER  
 HF-N-7-6-3. INSTALLATION ON BELL  
 206L, 206L-1, 206L-3, 206L-4, AND  
 407 ONLY

UP  
 LEFT  
 (VIEW LOOKING FWD)

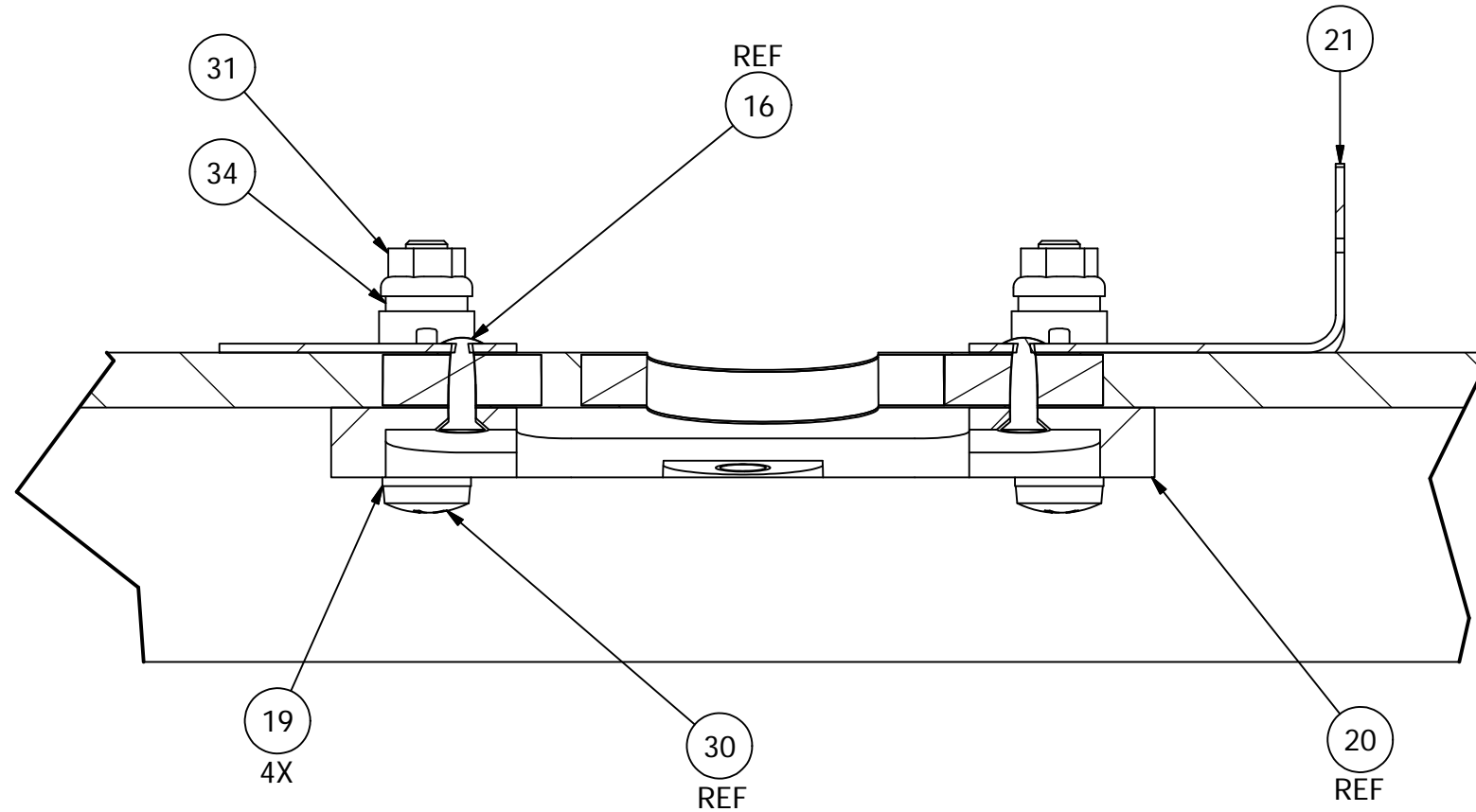

DETAIL AE

PROPRIETARY NOTICE  
 THIS DOCUMENT AND THE INFORMATION HEREIN ARE PROPRIETARY DATA TO HELIFAB AND ALL DESIGN, MANUFACTURING, REPRODUCTION, USE, PATENT RIGHTS AND SALES RIGHTS REGARDING THE SAME ARE EXPRESSLY RESERVED. THIS DATA IS SUBMITTED UNDER A CONFIDENTIAL RELATIONSHIP FOR A SPECIFIC PURPOSE AND NEITHER THIS DOCUMENT NOR THE INFORMATION CONTAINED HEREIN SHALL BE REPRODUCED, USED, OR DISCLOSED TO OTHERS



DRAWING NO:	HF-CA-7-6
LATEST REV/DATE:	IR / 01/25/2016
SHEET:	A-6

INSTALLATION PART NUMBER HF-N-7-6-3.  
 INSTALLATION ON BELL 206L, 206L-1, 206L-3,  
 206L-4, AND 407 ONLY

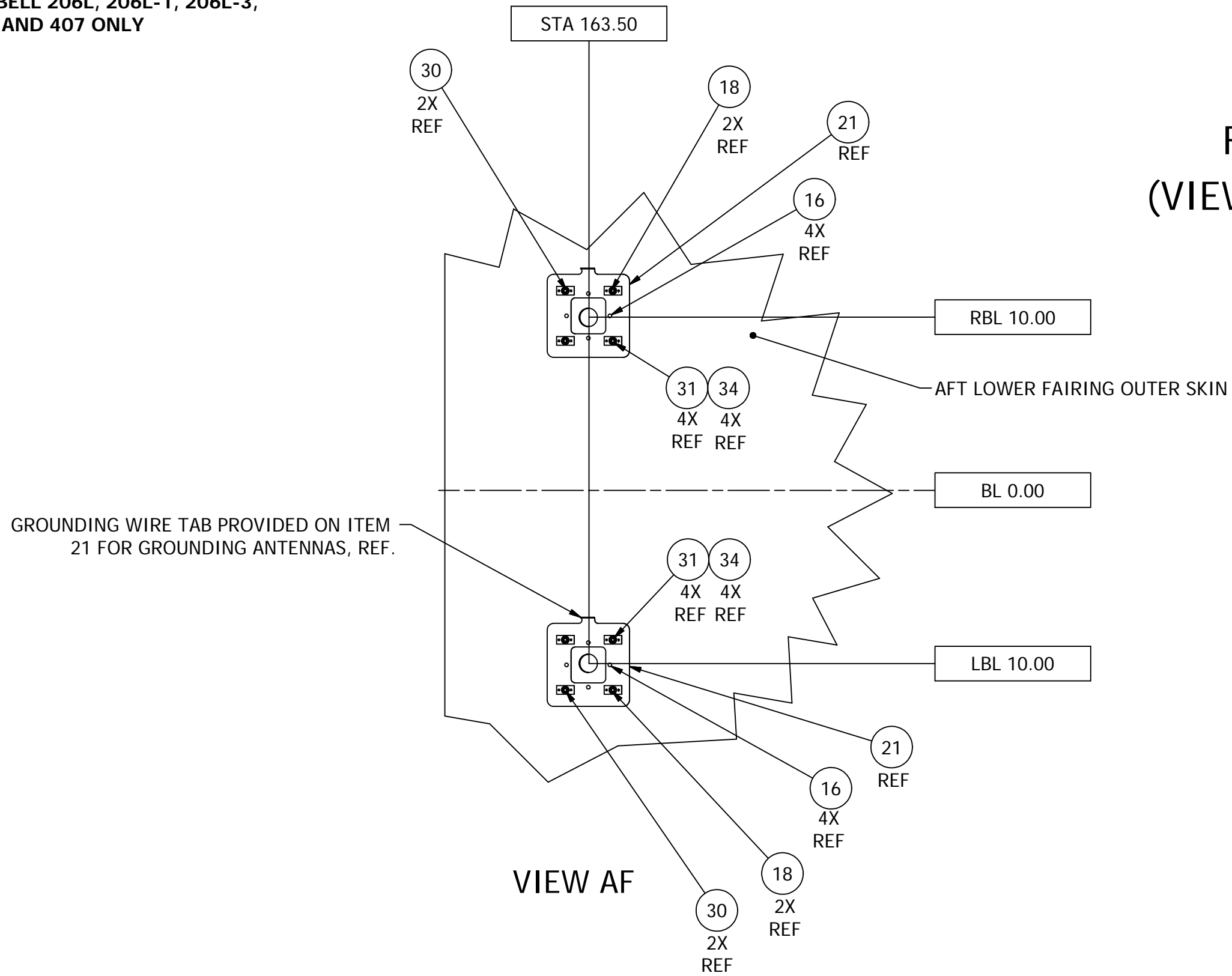

PROPRIETARY NOTICE  
 THIS DOCUMENT AND THE INFORMATION HEREIN ARE PROPRIETARY DATA TO HELIFAB  
 AND ALL DESIGN, MANUFACTURING, REPRODUCTION, USE, PATENT RIGHTS AND SALES RIGHTS  
 REGARDING THE SAME ARE EXPRESSLY RESERVED. THIS DATA IS SUBMITTED UNDER A  
 CONFIDENTIAL RELATIONSHIP FOR A SPECIFIC PURPOSE AND NEITHER THIS DOCUMENT NOR THE  
 INFORMATION CONTAINED HEREIN SHALL BE REPRODUCED, USED, OR DISCLOSED TO OTHERS



DRAWING NO:	HF-CA-7-6
LATEST REV/DATE:	IR / 01/25/2016
SHEET:	A-7

INSTALLATION PART  
 NUMBER HF-N-7-6-4.  
 INSTALLATION ON  
 BELL 206B ONLY

ANTENNA INSTALLATION  
 PROVISION ON AFT LOWER FAIRING

STA: 138.30

AH

AH  
 DETAIL AG

LHS  
 FWD  
 (VIEW LOOKING UP)

20

18  
 2X

19  
 4X

16  
 4X

30  
 2X

LBL: 10.00

24

27

19

10X 10X

BL: 0.00

RBL: 10.00

18

2X

19

4X

16

4X

30

2X

20

PROPRIETARY NOTICE  
 THIS DOCUMENT AND THE INFORMATION HEREIN ARE PROPRIETARY DATA TO HELIFAB  
 AND ALL DESIGN, MANUFACTURING, REPRODUCTION, USE, PATENT RIGHTS AND SALES RIGHTS  
 REGARDING THE SAME ARE EXPRESSLY RESERVED. THIS DATA IS SUBMITTED UNDER A  
 CONFIDENTIAL RELATIONSHIP FOR A SPECIFIC PURPOSE AND NEIGHER THIS DOCUMENT NOR THE  
 INFORMATION CONTAINED HEREIN SHALL BE REPRODUCED, USED, OR DISCLOSED TO OTHERS



DRAWING NO:	HF-CA-7-6
LATEST REV/DATE:	IR / 01/25/2016
SHEET:	A-8

DRAWING SIZE: B

SCALE: NTS

INSTALLATION PART  
 NUMBER HF-N-7-6-4.  
 INSTALLATION ON  
 BELL 206B ONLY

UP  
 LHS ←  
 (VIEW LOOKING FWD)

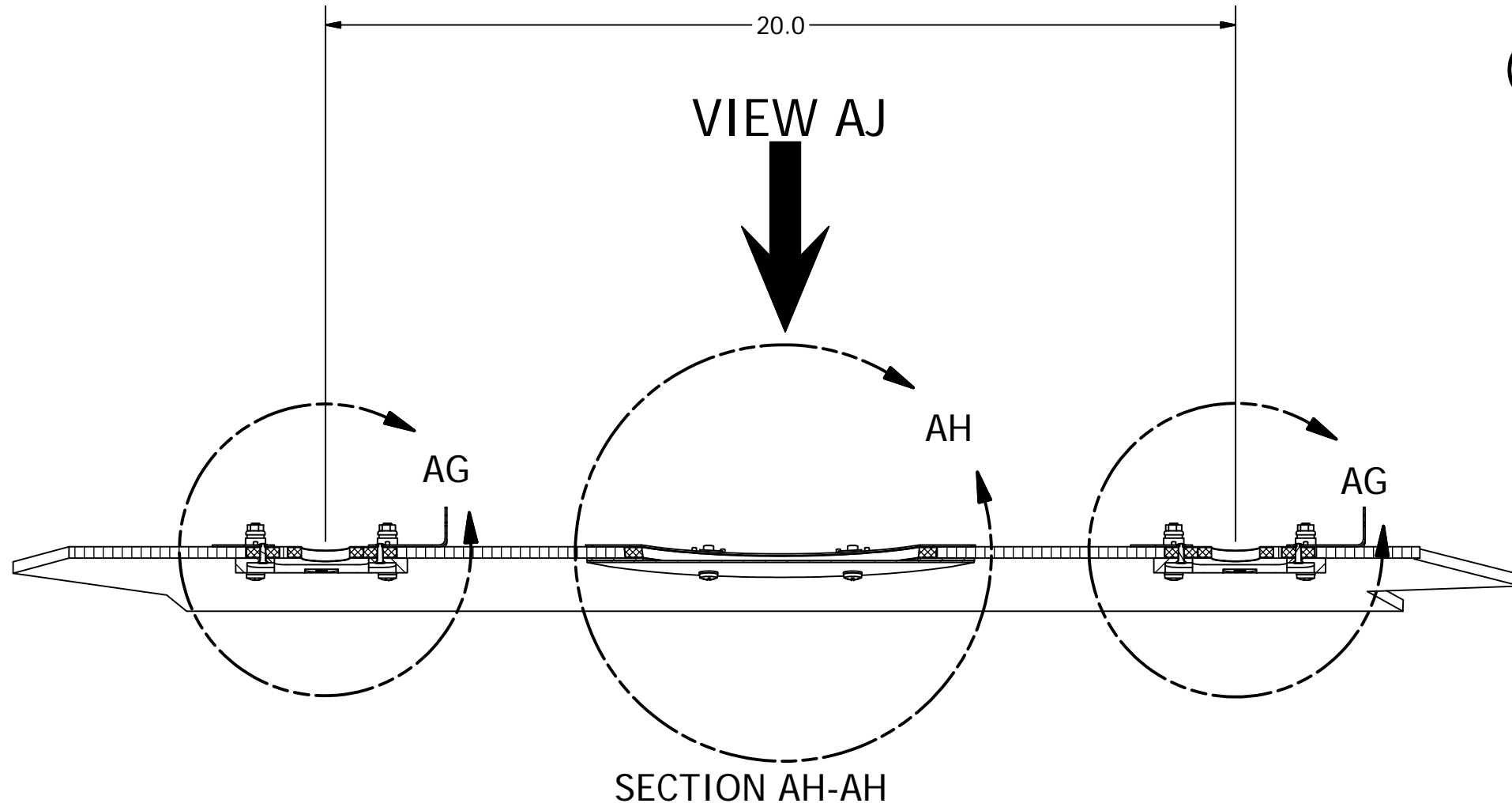

PROPRIETARY NOTICE  
 THIS DOCUMENT AND THE INFORMATION HEREIN ARE PROPRIETARY DATA TO HELIFAB AND ALL DESIGN, MANUFACTURING, REPRODUCTION, USE, PATENT RIGHTS AND SALES RIGHTS REGARDING THE SAME ARE EXPRESSLY RESERVED. THIS DATA IS SUBMITTED UNDER A CONFIDENTIAL RELATIONSHIP FOR A SPECIFIC PURPOSE AND NEITHER THIS DOCUMENT NOR THE INFORMATION CONTAINED HEREIN SHALL BE REPRODUCED, USED, OR DISCLOSED TO OTHERS



DRAWING NO:	HF-CA-7-6
LATEST REV/DATE:	IR / 01/25/2016
SHEET:	A-9

6 5 4 3 2 1

6 5 4 3 2 1

E  
D  
C  
B  
A

E  
D  
C  
B  
A

INSTALLATION PART  
 NUMBER HF-N-7-6-4.  
 INSTALLATION ON  
 BELL 206B ONLY

UP  
 LEFT  
 (VIEW LOOKING FWD)

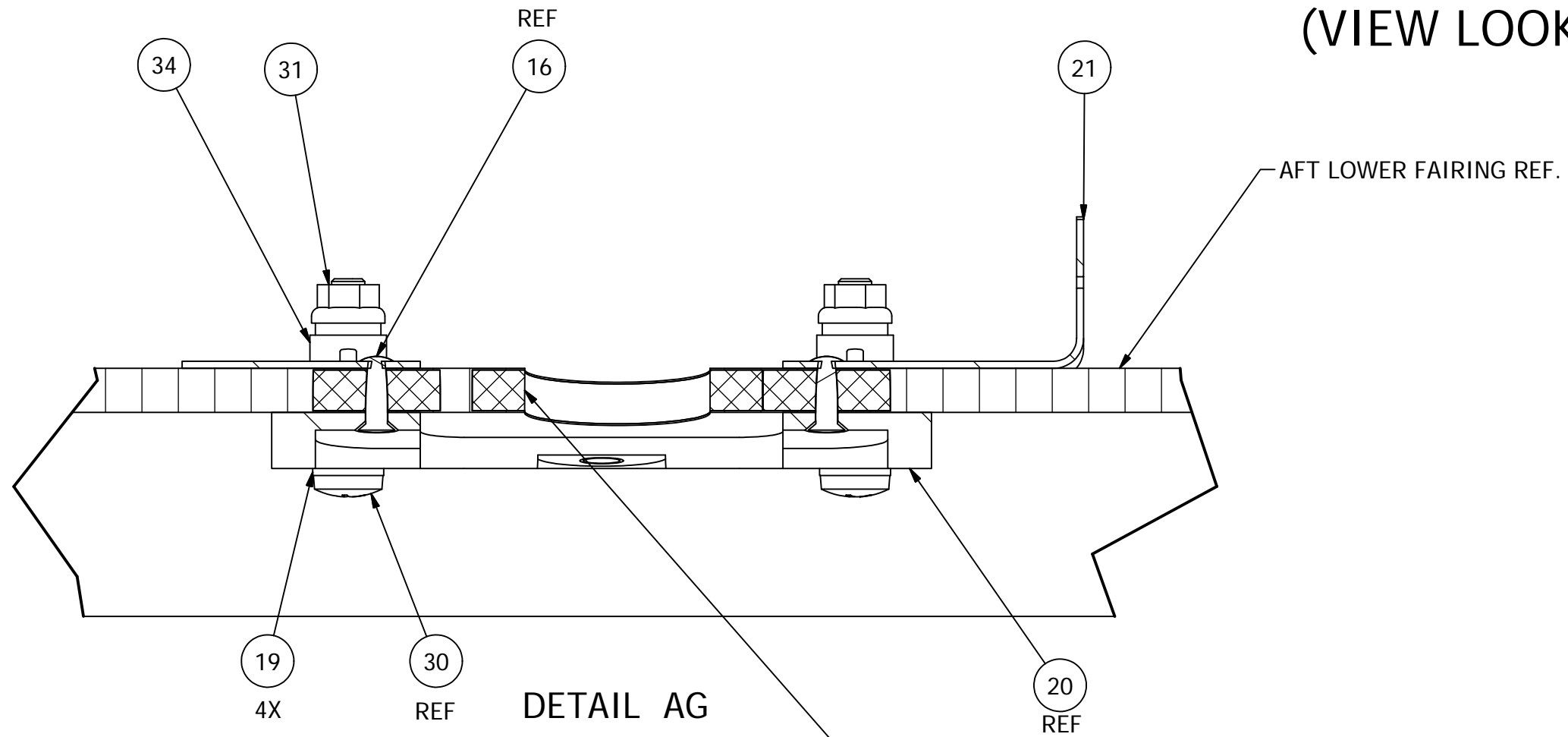

HOLES THROUGH AFT LOWER FAIRING  
 HARDPIONTED USING ADHESIVE, REF.

PROPRIETARY NOTICE  
 THIS DOCUMENT AND THE INFORMATION HEREIN ARE PROPRIETARY DATA TO HELIFAB  
 AND ALL DESIGN, MANUFACTURING, REPRODUCTION, USE, PATENT RIGHTS AND SALES RIGHTS  
 REGARDING THE SAME ARE EXPRESSLY RESERVED. THIS DATA IS SUBMITTED UNDER A  
 CONFIDENTIAL RELATIONSHIP FOR A SPECIFIC PURPOSE AND NEIGHER THIS DOCUMENT NOR THE  
 INFORMATION CONTAINED HEREIN SHALL BE REPRODUCED, USED, OR DISCLOSED TO OTHERS



DRAWING NO:	HF-CA-7-6
LATEST REV/DATE:	IR / 01/25/2016
SHEET:	A-10

6 5 4 3 2 1

6 5 4 3 2 1

E  
D  
C  
B  
A

E  
D  
C  
B  
A

INSTALLATION PART  
 NUMBER HF-N-7-6-4.  
 INSTALLATION ON  
 BELL 206B ONLY

UP  
 LHS ←  
 (VIEW LOOKING FWD)

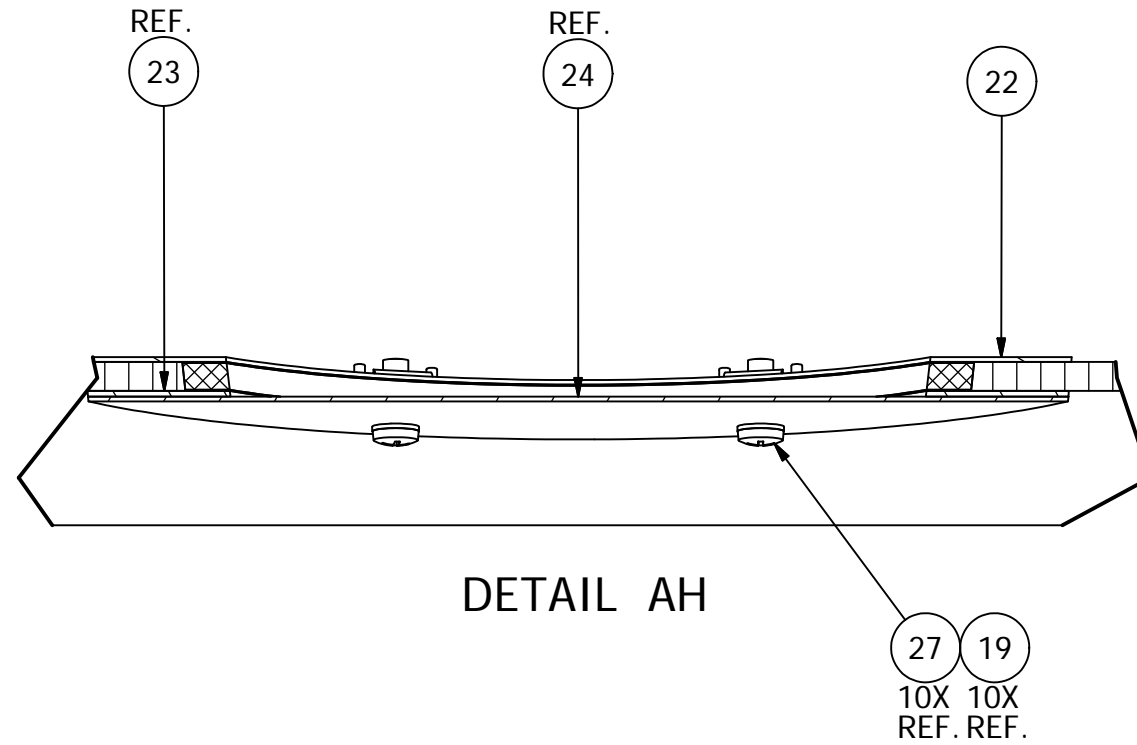

DETAIL AH

PROPRIETARY NOTICE  
 THIS DOCUMENT AND THE INFORMATION HEREIN ARE PROPRIETARY DATA TO HELIFAB AND ALL DESIGN, MANUFACTURING, REPRODUCTION, USE, PATENT RIGHTS AND SALES RIGHTS REGARDING THE SAME ARE EXPRESSLY RESERVED. THIS DATA IS SUBMITTED UNDER A CONFIDENTIAL RELATIONSHIP FOR A SPECIFIC PURPOSE AND NEITHER THIS DOCUMENT NOR THE INFORMATION CONTAINED HEREIN SHALL BE REPRODUCED, USED, OR DISCLOSED TO OTHERS



DRAWING NO:	HF-CA-7-6
LATEST REV/DATE:	IR / 01/25/2016
SHEET:	A-11

6 5 4 3 2 1

E  
D  
C  
B  
A

E  
D  
C  
B  
A

6 5 4 3 2 1

INSTALLATION PART  
NUMBER HF-N-7-6-4.  
INSTALLATION ON  
BELL 206B ONLY

GROUNDING WIRE TAB PROVIDED ON ITEM  
21 FOR GROUNDING ANTENNAS, REF.

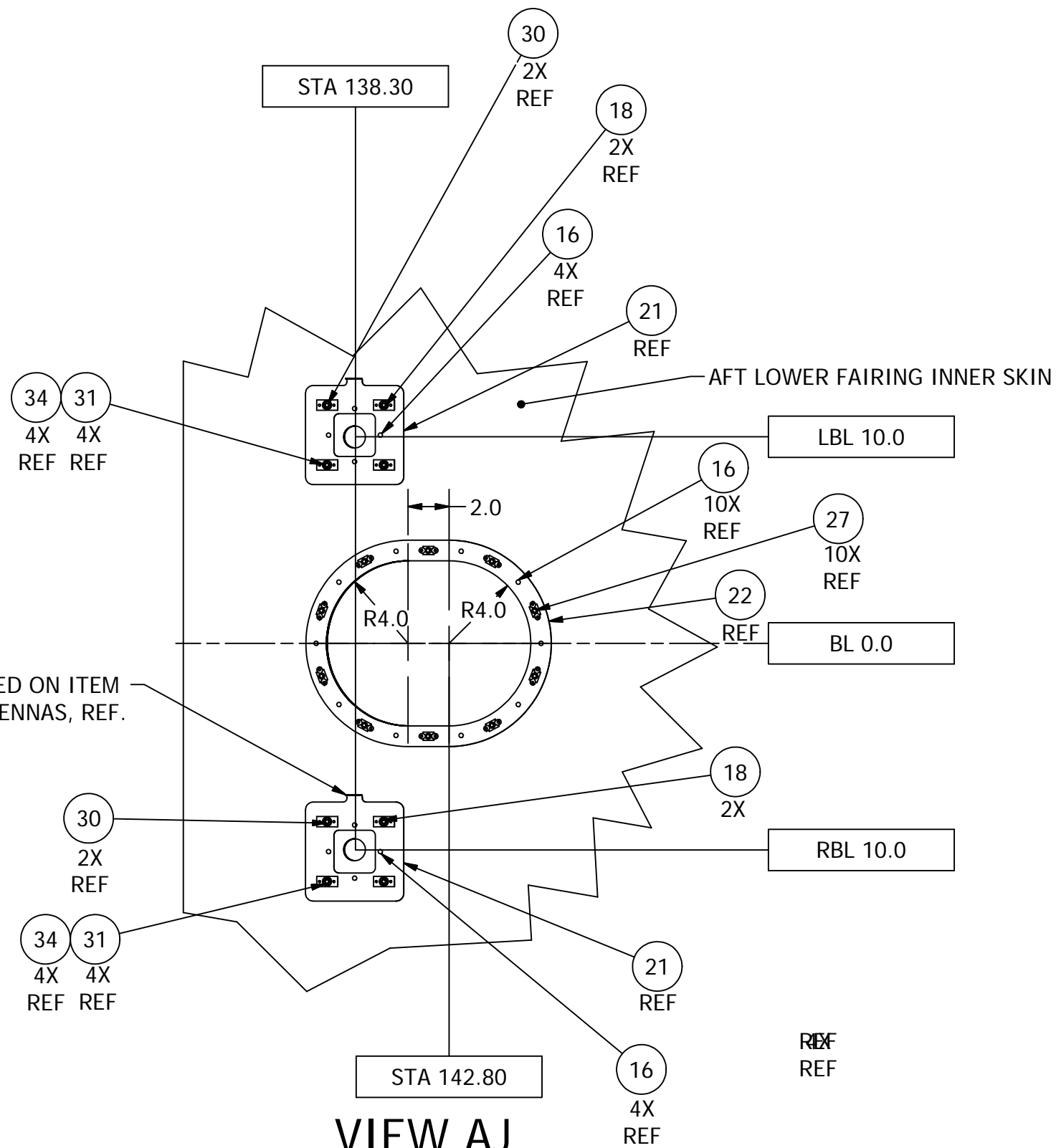

LHS  
FWD  
(VIEW LOOKING UP)

VIEW AJ

PROPRIETARY NOTICE  
THIS DOCUMENT AND THE INFORMATION HEREIN ARE PROPRIETARY DATA TO HELIFAB AND ALL DESIGN, MANUFACTURING, REPRODUCTION, USE, PATENT RIGHTS AND SALES RIGHTS REGARDING THE SAME ARE EXPRESSLY RESERVED. THIS DATA IS SUBMITTED UNDER A CONFIDENTIAL RELATIONSHIP FOR A SPECIFIC PURPOSE AND NEITHER THIS DOCUMENT NOR THE INFORMATION CONTAINED HEREIN SHALL BE REPRODUCED, USED, OR DISCLOSED TO OTHERS



DRAWING NO:	HF-CA-7-6
DRAWING SIZE:	B
LATEST REV/DATE:	IR / 01/25/2016
SCALE:	NTS
SHEET:	A-12